

## CONSIDERATION OF BIOMEDICAL FACTORS WHEN CALCULATING ARCHITECTURAL AND ARTISTIC LIGHTING

Pylyp Hovorov<sup>1</sup>, Plamen Tsankov<sup>2</sup>, Anastasiia Kindinova<sup>1</sup>

<sup>1</sup>OM Beketov National University of Urban Economy in Kharkiv

<sup>2</sup>Technical University of Gabrovo

### Abstract

*The work presents an assessment of the influence of architectural and artistic lighting on the general indicators of the human body, and developed methods of quantitative assessment of artistic lighting. Also, the effectiveness of the developed program and calculation methodology is shown on the example of the architectural and artistic lighting educational building of the Technical University of Gabrovo.*

**Keywords:** architectural lighting, artistic lighting, biomedical engineering.

### INTRODUCTION

Modern lighting technologies are based on the issues of saving fuel and energy resources, which is due to the wide development of lighting of the architectural and artistic system. One of the solutions to this problem is the transition to the use of energy-saving light sources, including their new generation - Light-emitting diodes (LEDs). This opens the possibility of introducing fundamentally new technologies in the field of architectural and artistic lighting, including, among other things, the generation of a wide spectrum of radiation and the high dynamics of its change. However, the use of such light sources requires, in turn, the development of a concept, models and principles for the construction and operation of lighting systems based on them, which are not currently available.

In our time, the following interrelated processes are observed in the field of lighting engineering:

- introduction of LED devices into installations of architectural and artistic lighting with a maximum demonstration of their lighting and colorimetric capabilities;
- aiming of developments in the direction of taking into account the influence of light space on the biological state of a person;
- development and implementation of dynamic color modes in lighting systems.

These processes require the definition of performance evaluation criteria and principles for constructing LED lighting installations.

As a criterion for the efficiency of lighting installations, only one is currently considered - the economic criterion. At the same time, in modern conditions around the world, a very urgent problem is the impact of the external environment on human health. In recent years, there has been a transition of short-term changes in the state of health under the influence of a negative environmental impact (acute diseases) into chronic relapsing forms. However, well-known publications practically do not present scientifically based economic criteria for assessing the impact of environmental factors on public health, including light and color pollution.

The researchers also found that the radiation of the optical spectrum provides not only the visual process, but also participates in the functioning of many other organs of the human body. Despite this, there is still no data on how to quantify this phenomenon and take this fact into account when designing lighting systems. The study of circadian rhythms has led to advances in lighting technology, specifically in the field of indoor lighting. But even it is imperfect, since only those properties that are perceived directly by sight are considered. Unfortunately, these studies are

not relevant for outdoor lighting. [1,2]

In addition, studies were carried out on the influence of lighting brightness on the development of myopia and erroneous myopia, as well as measures to minimize their impact. However, they do not take into account the dynamics of light and color modes of lighting installations.

That is, it can be said that all existing studies are more intended for indoor use and cannot fully take into account all aspects of external architectural and artistic lighting. This is superimposed by the complexity of visual perception, which requires a much more complete account of the impact of the light environment on the human body, and also requires focusing on taking into account the light-color effect of the environment, where an important role is played by colorimetric characteristics in the psychosomatic state of the organism. In addition, the introduction of LED emitters in lighting installations emphasized the particular importance of this factor in influencing the emotional and physical state of a person. [3,4]

The psychosomatic state of the body is very important, since the final recipient of information, its perception and transformation are precisely the neurons of the brain, and, accordingly, taking into account the color of the light environment and, in general, taking into account its harmony are categorically necessary and are of great importance and influence on the human body.

All this confirms the high level of impact of the light environment on the general condition of the human body and the need for increased attention to more light characteristics of architectural and artistic lighting.

## EXPOSITION

The set of electrical networks and power sources designed to supply electrical energy to electrical consumers of lighting combines the system of power supply and lighting of cities. A feature of this combination is the integrated supply of consumers of electricity and lighting, which determines the unity of processes in them. Therefore, combining them within a single system with a single management allows you to optimize the processes in them. Moreover, the influence of

lighting on processes in the living and plant world shows this system as a biotechnical type system, and the intellectualization of its individual control - its belonging to Smart-Light systems.

Thus, this concept of controlling the modes of lighting systems will allow taking into account their features related to taking into account the color and light effects on the animal and plant world, as well as the higher-level systems associated with them - electric power systems and networks. Under such conditions, the presence of the noted features makes it necessary to separate urban lighting systems into an independent Smart-Light system of a higher level, which combines the Smart-Grid system and the life support system of the city as a whole. The structure of such a system is shown in Figure 2. It includes a power system, a power supply system, which is a complex of lighting installations with a control system, built on the basis of the Smart-Grid concept, as well as an electric lighting system as an integral part of the city.

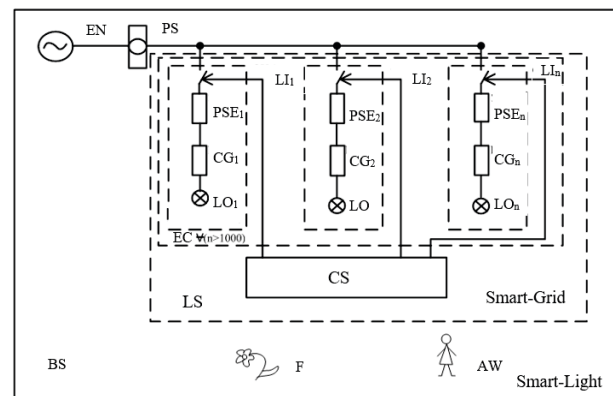

**Fig. 1.** Biotechnical lighting system.

\* EN - electrical network, I - power source, ZE - protective and switching equipment, control equipment ~ starting and control equipment, LO - light sources, LI - lighting installations, EC - electrical complex, SU - control system. LS - lighting system, F - flora, AB - wildlife, BS - biotechnical system.

The quantitative assessment of the light-color effect of lighting on the human body belongs to the border areas of several scientific areas, which are characterized, on the one hand, by indicators that are difficult to directly diagnose, and on the other, by the functional transformation of these indicators. A characteristic feature of light-color exposure is

that its result is not point and static measurements of the state of the body, but dynamic characteristics of processes with their change in time.

The purpose of modeling is to develop a methodology and model for a comprehensive quantitative assessment of the impact of a light-and-color environment on a person, ensuring that its laws are taken into account when creating installations for architectural and artistic lighting. The color load was chosen as the main parameter of the light environment. Here the main role is played by the properties of the lighting installation, color reproduction, properties of the illuminated environment, color combinations, reproduction dynamics, transition effects and oscillation frequency.

The first step in assessing the light-color effect of lighting on the psychosomatic state of a person was color coding and the construction of a color space that maximally matches the range of color vision of the human visual analyzer.

The experiment used a setting with a digital description of the color space, which provides flexibility in the colorimetric capabilities of the system and the ability to create a software environment for reproducing a wide range of color modes. For this, the authors have developed an electrophysiological hardware-software complex that provides registration of the feedback of the main physiological parameters of the body to a light stimulus and reproduction of this stimulus. As part of this task, the following were developed:

- hardware part of the complex;
- algorithmic and software coding of color space;
- system of reproduction of color dynamic modes.

The installation includes a color-forming system based on a personal computer AMD Athlon 64 Processor 3000+, 1.81 GHz, 1.00 GB of RAM, an analog electroencephalograph EE84-2-05, a heart rate monitor, and a sphygmomanometer. The LCD monitor was selected as the initial color signals of the installation - Samsung SinkMaster 740n. The screen resolution used during the experiment was  $1280 \times 1024$ , the refresh rate was 75 Hz [6]. The color rendering unit was installed

perpendicular to the observer's line of sight at a distance of 1–1.2 m.

The use of a setting with a digital description of the color space, which provides flexibility in the colorimetric capabilities of the system, made it possible to create a software environment for reproducing a wide range of color modes for experiments.

In well-known works [5,6], a computer monitor was also used as an element of visual influence, but this is a monitor of the “cathode ray tube” type. The choice of visualization system in the experiments conducted by the authors is due to the following main reasons:

1. When displaying an image on the screen, it is necessary to take into account the sharpness of the display system. In LCD monitors, the sharpness index depends on the size of the source (LCD backlight), the primary image receptor (screen), the secondary image receptor (screen matrix), and the movement of the reproduced object (light-colored figures). In relation to light, the matrix is a passive element that modulates the radiation passing through it.

2. The selected visualization system does not have such a disadvantage as geometric distortions typical for systems with cathode ray tubes.

3. The LCD monitor is devoid of screen flicker and electromagnetic radiation, provides a minimum effect of technical and optical parameters on the observer and allows you to create the highest quality light-color space during the experiment.

4. The visual evaluation of image reproduction is affected by the level of brightness, the sharpness of the border of the transition from dark to light, the complexity of the observed scene, the physical condition of the observer, etc. In the experimental setup, brightness and contrast are adjustable values, and the displayed image does not have a complex shape and is presented field color only.

5. The normalized time scale of the imaging system used is the monitor response time of 8 seconds. However, the visual tasks of the experiment do not require strict restrictions on this characteristic, and therefore, it is possible to include devices with a long response time in

the complex, which have little effect on the change in color modes over time.

The feedback recording system was assembled from the systems of the human body as a monitoring system. Electroencephalography (EEG) of four lobes of the brain pulp made it possible to register the primary reaction of the central nervous system to impulses caused by a color stimulus. The electrical activity of the brain was analyzed for each lobe of the brain in terms of frequency and amplitude. Registration was carried out on an analog electroencephalograph EE84-2-05.

To record instantaneous indicators of the body's reaction to a light stimulus by changing the work of the cardiovascular system, the pulse was recorded during the experiment.

In addition to the direct reaction of the body to any changes in the surrounding space, in particular the light and color environment, there are also such reactions that can be tracked only when a person stays in this space for a long time. In the course of research, to determine the reaction of the body during a long stay in the light-color space, changes in blood pressure were recorded as a feedback of the body.

The experimental technique provides for the registration of changes in the physiological parameters of the body depending on changes in the parameters of the light-color medium. Experimental studies focused on:

- assessment of the degree of influence of each factor on the human condition;
- determination of the area of the factor space, the most favorable for the human body.

In accordance with the goals and objectives set, a research algorithm was developed, according to which the following assessments were carried out:

- pulse rate
- changes in systolic and diastolic pressure;
- change in electroencephalogram parameters depending on the following colorimetric characteristics of the light space:
  - characteristics of the total vector of colors, mixed, chromaticity coordinates (aR + bG + cB);
  - brightness of the color field;
  - color saturation.

At the same time, the estimates were also studied:

- time of color impact on a person;
- age of the person;
- gender of a person in response to a change in color space.

In the course of experimental studies, a software environment was developed for reproducing color modes, the coordinates of which lie in the chromaticity region of the radiation of modern LED light sources.

Mathematical models of statistical processing of research results made it possible to develop quantitative estimates of the impact of the light-color environment on the human body for different age groups of observers (for example, the range of 20-30 years is taken), which take into account the influence of architectural and artistic lighting on impulse, pressure and observation systems. The general view of the pulse and pressure models of a group of observers is presented below (equations (1)-(3)):

$$Y_{1_{20-30years}}(x_1, x_2, x_3) = 1,4433x_1^2 + 0,7659x_2^2 + 0,4272x_3^2 - 5,6 \times 10^{-17}x_1x_2 - 5,6 \times 10^{-17}x_1x_3 - 5,6 \times 10^{-17}x_2x_3 + 11,728x_1 - 2,419x_2 - 5,642x_3 + 2,0016 \quad (1)$$

$$Y_{2_{20-30years}}(x_1, x_2, x_3) = -0,4622x_1^2 + 0,520035x_2^2 + 1,061958x_3^2 - 1,11 \times 10^{-16}x_1x_2 - 1,11 \times 10^{-16}x_1x_3 - 1,11 \times 10^{-16}x_2x_3 + 2,474104x_1 - 0,82447x_2 - 3,18833x_3 - 0,75097 \quad (2)$$

$$Y_{3_{20-30years}}(x_1, x_2, x_3) = -0,27173x_1^2 - 0,06851x_2^2 + 0,405669x_3^2 + 2,052052x_1 + 1,612425x_2 - 2,5282x_3 - 3,725566 \quad (3)$$

Where  $Y1$ -change in pulse rate  $Y2$ ,  $Y3$  - change in systolic and diastolic pressure, respectively;

The following are considered as variable parameters:

- $x1$ - chromaticity coordinate a;
- $x2$ - chromaticity coordinate b;
- $x3$ - chromaticity coordinate c;

The use of various models for controlling the operating modes of architectural and artistic lighting systems has made it possible to increase its efficiency by introducing feedback on the quality of lighting.

Based on these data, the concept of architectural lighting for the building of the Library of the University of Gabrovo was developed. A building model was developed and a lighting project was completed in the Dialux Evo program; to create such images in

software products, the methods of computer graphics Radiosity and Raytracing are used. The simulation results are shown in the Figures 2, 3 and 4.



*Fig. 2. - Inspection point 1*



*Fig. 3. - Inspection point 2*



*Fig. 4. - Viewpoint 3*

On Figures 6 and 7 show images in fictitious colors for illumination, and in Fig. 7 for brightness.

After analyzing the given data, we can say that the levels of brightness and illumination that were accepted were met. It should also be noted that there is no glare at the viewpoints either.

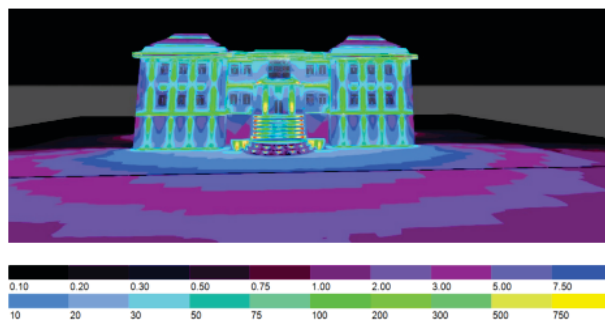

*Fig. 5. - Fake colors of illumination, view 1*

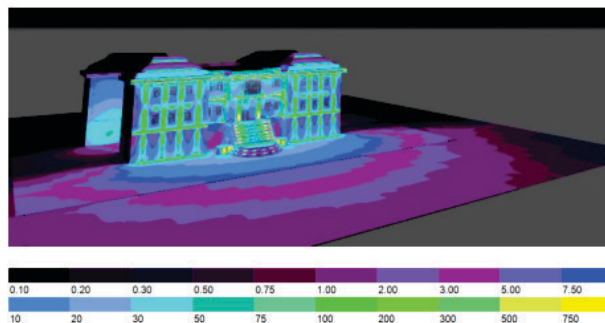

*Rice. 6. - Fake illumination colors, view 2*

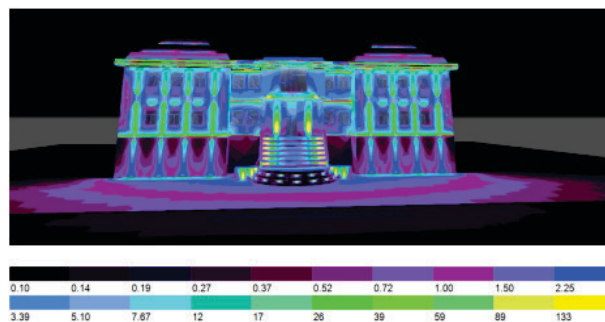

*Rice. 7. - Fake Luminance Colors*

When developing the concept, all the above was taken into account.

After analyzing the viewpoints, it was decided to illuminate the front of the building, as well as highlight the rear of the building, which will be visible from the selected points.

In detail, the need to focus on:

- three-dimensional elements of the main facades between the windows;
- eaves;
- columns;
- signs "UNIVERSITY LIBRARY";
- stairs;
- roofs.

It is these parts that need to be exhibited, but due to the geometry of the building, it was decided to place more emphasis primarily on the side and central facades, and reduce the

distance on intermediate accents. Concerning the side facades connecting the favorites, on the contrary, it was decided to hide them as much as possible, in order to create a larger volume of the building from all points of view. [6]

Since the facade of the building and the roof have warm colors, it is the lighting that should first of all be with a low color temperature, and its color should belong to the warm region of the spectrum. Considering that a third of the façade is rather dark, the roof is terracotta and the environment is also made of fairly dark materials, it was decided to use white fixtures with a color temperature of up to 3000 K to compensate for the dark and bright elements and to provide a spectacular effect. the image of the building and the creation of a comfortable atmosphere.

Therefore, we can say that the concept of creating soft and comfortable lighting has been adopted. This decision was made on the basis of a statistical study of human perception of the architectural environment.

Regarding lighting methods, it was decided to apply the spot method to the main facades, and the flood light method for the rear ones. Thus, it will be possible to focus on the architecture of the building and create a holistic image without separating individual parts of the building.

The entrance, framed by columns and topped with a golden inscription, was chosen as the main point of attraction for the eye. This is due to the fact that this is the central element of the building and at first glance it will be clear what kind of building it is. The focal points are the three-dimensional elements of the facade, cornices and stairs.

In addition, it was customary to create a rhythmic lighting of the main facades, which

harmonizes with the columns and creates a single image of the architectural object.

## CONCLUSION

1. The conducted research allowed to develop models for the quantitative assessment of the light and color effects of architectural and artistic lighting on the psycho-somatic state of a person.

2. The application of the developed model in the design of the system of architectural and artistic lighting of the building of the Library of the Technical University of Gabrovo made it possible to create an architectural and artistic lighting system that meets the aesthetic, medical and biological requirements.

## REFERENCE

- [1] V. Zhagan, Illumination of objects. EKOinform, 2006, 242 p.
- [2] P. Hovorov, V. Chernets, "Accounting for the biomedical factor in the design of decorative and artistic lighting installations." Proceedings of the international scientific and technical conference "SWYATLO 2006". Warsaw: Soma, September 21-25, 2006, pp. 32-38.
- [3] Y. Eisenberg, The art of lighting the city. M.: Znak, 2002, p 112.
- [4] Van Bommel, Van den Beld, Provides work: through visual and biological effects. Lighting Research & Technology, 2004.
- [5] P. Hovorov, V. Chernets, "Electrophysiological complex for the correction of the psychosomatic state of a person." Proceedings of the International Scientific and Technical Conference on Light Engineering and Energy, Gabrovo, October 23-25, 2006, pp. 152-158.
- [6] D. Miloslavsky, A. Shushlyapin, O. Shushlyapin, "Complex magnetic and color therapy at the initial stages of hypertension." Proceedings of the Second International Symposium "Biophysics of fields and radiation and bioinformation", Tula, 1999, p 25.