

GRAPHICAL REPRESENTATION OF BASIC ELECTRICAL POWER QUANTITIES MEASURED WITH POWER LOGIC PM5000 SERIES

Marko Rosić¹, Uroš Pešović¹

¹ University of Kragujevac, Faculty of Technical Sciences Čačak, Serbia

Abstract

The paper describes the realization of the recording device of basic electrical quantities of power supply, acquired by the power meter PM5110 through Modbus serial communication. The developed "RecMod2021" device is based on an Arduino microcontroller board programmed to read registers of PM5110 during specific time recording patterns and store the data in the SD card using a desirable file format. Data stored on an SD card is further used for graphical representation of measured time-instantaneous and time-averaged electrical quantities such as line or phase voltage, current, frequency, active, reactive, apparent power, THD, power factor, etc. through ACLoadView software. The ACLoadView software allows offline parameters observation and analysis in numerical and graphical terms, towards tracking potential malfunctions of the testing equipment of which counted electrical quantities are measured and recorded. ACLoadView allows generation of final report in pdf format at the end of the testing procedure.

Keywords: PM5110 power meter, data logging, Modbus, ACLoadView software.

INTRODUCTION

Measurements in electrical engineering are quite represented and in use in various forms and applications. Measurement equipment is an unavoidable part of every electrical engineering laboratory usually represented through various types of multimeters designated for different purposes [1].

Today a large number of multimeters can be found on the market suitable for various needs in electrical engineering measurement. A typical multimeter can measure voltage, current and resistance. Nowadays, multimeters are usually digital and able to measure numerous electrical and nonelectrical quantities with different accuracy. Multimeters designed to measure electrical power, usually referred to as power meters, can measure active and reactive power, power factor, and other characteristic quantities that define the quality of the power supply.

However, the price of this measuring equipment is directly proportional to its accuracy, data processing and recording capabilities. In that sense, the idea for this paper arose from need to find a relatively cheap way to measure electrical power

quantities with satisfactory accuracy and recording possibilities. This paper presents the development of the RecMod2021 logging device which is capable to collect data measured with PM5110 power meter and store it to an SD memory card after which these data can be graphically presented.

DATA LOGGING MULTIMETERS

Power meters are specialized multimeters used for active and reactive power monitoring. They usually provide the measurement of power factor, frequency, current and voltage and their higher spectral components presented in the form of total harmonic distortion (THD) or percentage share of each harmonic. This PM5110 device is a flush-mount energy meter with a 96 mm by 96 mm backlit LCD as it is shown in Fig. 1. The meter provides Class 0.5S accuracy per IEC 62053-22 standard and 64 samples per cycle. The meter will measure Energy, Active and Reactive Power, Voltage, Current, Frequency, Power Factor and up to 15th harmonics [2]. The meter will function in a 50Hz or 60Hz network and accepts supply voltage ranging from 100 to 415 VAC and 125 to 250 VDC. Line rated current for this meter

is 1A or 5A input and will support Single Phase and Neutral, Three Phase, or Three Phase and Neutral configurations. The range of measurement voltage between Phases is 35 to 690 V AC at 47 to 63 Hz. The measurement range between Phase and Neutral is 20 to 400 V AC at 47 to 63 Hz. The communication protocol is Modbus RTU and ASCII 2 wires with RS485 port support.



Fig. 1. PM5110 power meter

Unlike the PM5110, which does not have an option to store data, different power meters with data logging options can be found on the market. Also, there are meters with larger LCDs in colour with a modest real-time graphical representation of measured electrical quantities. Moreover, high-quality measurement equipment with sophisticated data processing analysis options is usually followed with built-in high-power processors, or as a modular power meter setup with a separate high-resolution display or PC and DAQ controller, or specific PLC responsible for data processing, analysis and visualization [3]. Nevertheless, all these kinds of equipment are characterized by high prices. Even meters with characteristics equivalent to PM5110 but with data logging possibilities are at least twice costly in comparison with PM5110.

This paper presents the realization of the “RecMod2021” low-cost device based on the Modbus communication protocol designed to read and save electrical quantities measured with PM5110. Appropriate PM5110 registers are read and stored on an SD card in CSV file format. Time-stamped data on the SD card are stored in a specific pattern which further allows a simple read and appropriate graphical

representation of the recorded data and its analysis.

THE RECMOD2021 LOGGING DEVICE

Realized RecMod2021 logging device is based on an ATmega168 microcontroller located on an Arduino Nano board. This 8-bit RISC microcontroller has 16KB of FLASH memory for the program and 1KB of RAM and 512B of EEPROM memory for data storage. The microcontroller communicates with the PM5110 panel meter as a Modbus master [4] using the RS485 module. Received data are stored on an SD memory card which is connected to a microcontroller using the SPI protocol. Simplified structural diagram of realized RecMod2021 logging device is shown in Fig 2.

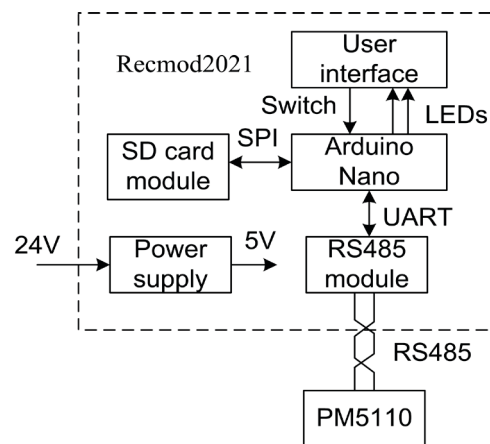

Fig. 2. Structural diagram of RecMod2021

Communication on the UART port is configured to the 8N1 data format, with a baud rate of 19200 bps. PM5110 slave address is set to 1 and the real-time clock registers are read from the PM5110 slave to check device presence. Then the SD card is initialized and a new CSV file is created with the predefined header. The name of the CSV file is given in the format Data_XYZ.csv, where XYZ is the decimal number of the log file which is stored in EEPROM and is incremented for every new logging file. Data logging starts when the user activates the recording switch (switch START at Fig.3), which periodically appends PM5110 data to a CSV file. The acquisition period is configurable and currently is set to one second as the shortest due to slow communication speed over RS485 line. During the acquisition interval the microcontroller first reads real-

time clock registers, after which the number of measurement registers is read from the PM5110 slave, and data is appended to the CSV file. Table 1. represents the list of the measurement parameters which are read from the PM5110 slave. Parameters are read using the five Modbus telegrams [5] for reading multiple holding registers, starting from the register base address and reading the consecutive number of registers [6]. Real-time clock values are read in unsigned integer format, while the electrical values are read in 32-bit floating point format.

Table 1. List of PM5110 parameters read

Parameter	Register base address	Registers read
Real-time clock	1837	7
Currents	3000	12
Voltages	3020	18
Powers (PQS)	3054	32
Frequency	3110	2

When the user stops the recording using the switch, the current logging file is closed and the file number is incremented in EEPROM, so the new recording will be appended to a new CSV file.

RecMod2021 logging device housing is printed on the 3D printer using the ABS filament suitable for mounting onto the DIN rail. The designed 3D model is shown in Fig 3, while the photographs of the realized device are shown in Fig 4.

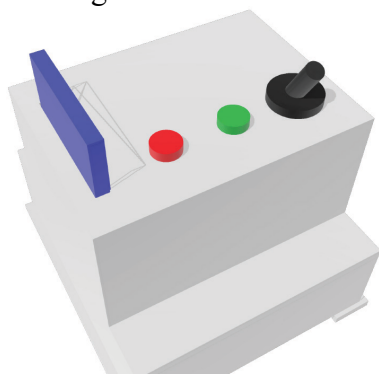

Fig. 3. 3D model of RecMod2021 logging device

Fig. 3 shows first version of the realised RecMod2021 device with SD card inserted. Beside the START switch, placed on the right side of the device, there are two visible LED confirming power supply presence (green) and recording in process (red). When device is successfully logging the data to the SD card,

recording LED will be permanently on. In case of the any communication error, such as absence of SD card when recording has started, recording LED will blink rapidly.



Fig. 4. Final look of the developed RecMod2021 device - ver. 1

ACLoadView SOFTWARE

The ACLoadView software (Fig. 5) can be freely downloaded from the official Hillstone load banks web page [7]. It was purposely developed as an accompanying diagnostic software of the high-power load banks whose main purpose is load regulation to prevent generator wet stacking due to low load on a diesel engine. The ACLoadView software allows time stamped graphical and data reporting of the load delivered during the load bank operation. This allows user subsequent analysis of the recorded power supply quantities and potential irregularities notation during the load test, which could be quite helpful in isolation of the problem origin.



Fig. 5. ACLoadView start screen

After the software is started, main options related to testing results are available such as import and load of the new results together with the overview of previously recorded measurements as it is depicted in Fig. 6.

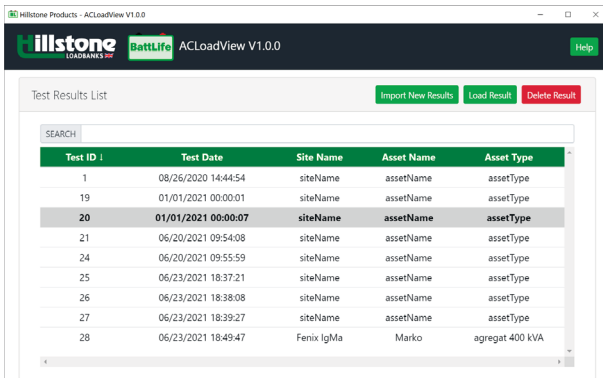

Fig. 6. Previous results list and import of the new results

After the results are imported from the SD card and loaded, a window with test results, testing equipment (in this case a diesel generator) information and other related details are shown (Fig. 7).

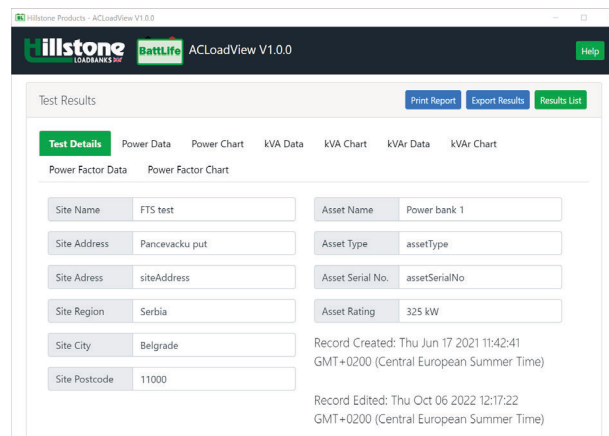

Fig. 7. Test results with test details window

Fig. 8 shows the power chart of all selected data graphically represented during the recording period and marked with different colours. The power chart window allows users to switch off or switch back on the particular electrical quantity representation, by its selection at the top of the graph. This option is quite useful during electrical quantity transition period analysis and generator malfunction tracking and solving.

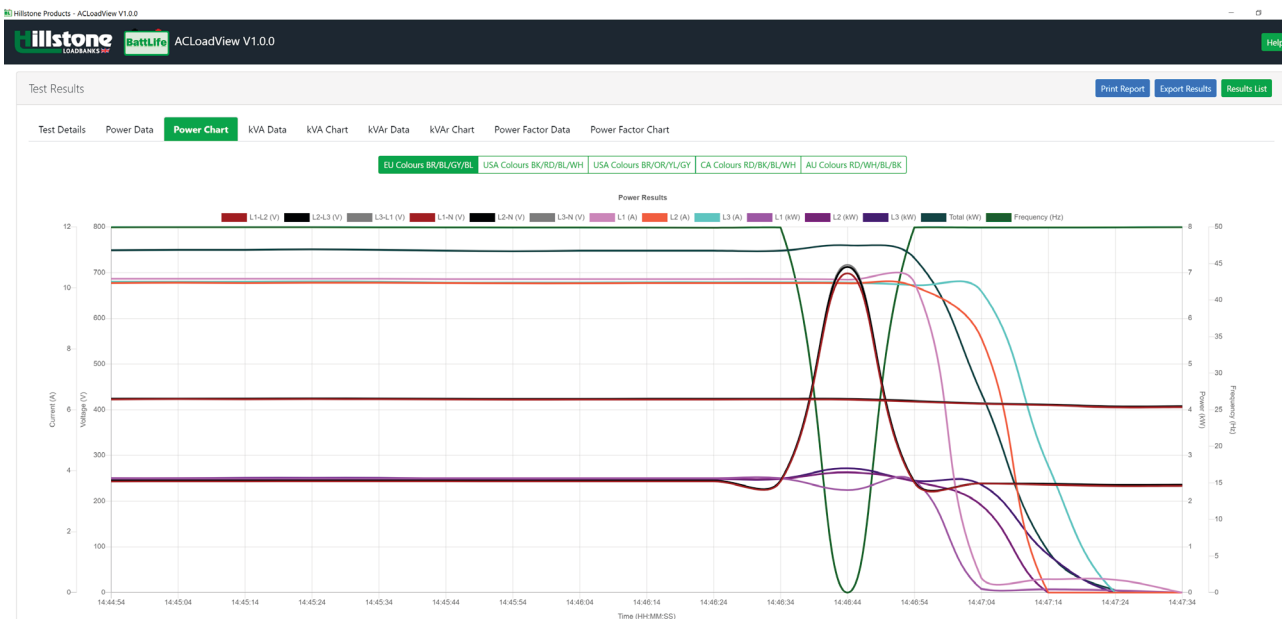

Fig. 8. Graphical representation of the results

After the analysis of testing results is done, the ACLoadView allows printing of the test report (Fig.9). The test report consists of basic test details with numerical and graphical test result representation. The generated PDF test report can be printed and joined accompanying documentation of each tested device as a proof

of their performances during various load and under on-site real testing conditions.

Nevertheless, since all measured and recorded electrical quantities are saved on SD card in CSV file format, they can easily be graphically represented in any other available software allowing graphical visualisation of

numerically stored data such as MS Excel, Origin, DatPlot, etc.

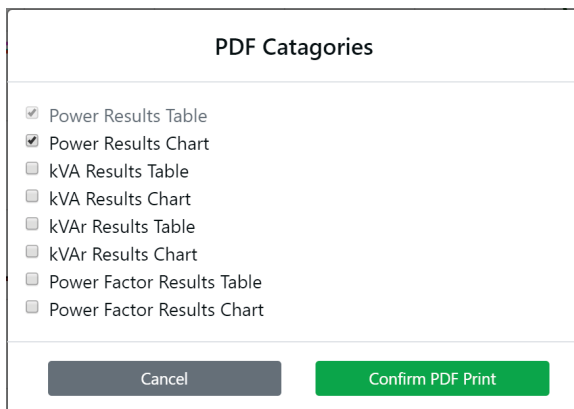

Fig. 9. PDF report generation

CONCLUSION

The paper presents a low budget solution of how basic electrical power quantities can be read from the PM5110 power logic meter, recorded and further graphically represented and analysed. The RecMod2021 device based on Modbus communication protocol is developed and described in this paper. Consisting parts of the realised RecMod2021 device are presented together with detailed description of how appropriate registers of the PM5110 meter are read and stored on the SD card in CSV file format. At the end of the paper an ACLoadView software is presented together with the description of its options related to graphical representation and report generation of recorded electrical quantities during the diesel generator testing by load bank.

ACKNOWLEDGEMENTS

This study was supported by the Ministry of Education, Science and Technological Development of the Republic of Serbia, and these results are part of the Grant No.451-03-68/2022-14/200132 with University of Kragujevac, Faculty of Technical Sciences Čačak.

REFERENCE

- [1] Tyler Saunders, Understanding the Different Types of Digital Multimeters, Available online: oct. 2022, <https://www.toolnerds.com/types-of-digital-multimeters/>
- [2] PM5110 metter data sheet, Available online: <https://www.se.com/ww/en/product/METSEPM5110/pm5110-meter-modbus-up-to-15th-h-1do-33-alarms/>
- [3] Matuschek power analysers, Available online: <https://www.matuschek.de/power-analyzer/overview.htm>
- [4] Modicon inc, Modbus Protocol Reference Guide, June 1996, Available online: oct. 2022, https://modbus.org/docs/PI_MBUS_300.pdf
- [5] MODBUS Organization, MODBUS over Serial Line Specification & Implementation guide V1.0, 2002, Available online: oct. 2022, https://modbus.org/docs/Modbus_over_serial_line_V1.pdf
- [6] PM5100_PM5300 Register List v01.00.0, Available online: oct. 2022, https://www.se.com/ww/en/download/document/PM5100-PM5300_PublicRegisterList/
- [5] HillStone load bank web page. Online available sept. 2022: <https://hillstone.co.uk/>