

**ANALYSIS OF SC, EGC AND MRC MACRO DIVERSITY SYSTEMS**

**Borivoje Milosevic**

*University MB, Belgrade, Serbia*

**Dusan Regodic**

*University MB, Belgrade, Serbia*

**Slobodan Obradovic**

*ITS, Belgrade, Serbia*

**Abstract:** *This paper will consider the analysis of signal transmission in the presence of a number of different noises and disturbances - fading. To reduce the impact of fading on system performance, MRC, EGC and SC diversity techniques will be used. The paper will show that the quality of the transmission can be significantly improved with the diversity technique. This method of improving the quality of signal transmission is successfully applied in wireless telecommunication systems and mobile telephony.*

**Keywords:** Signal Propagation, Diversity, SC, EGC, MRC, PDF, CDF, BER acquirement.

**INTRODUCTION**

Digital telecommunication signals, during their propagation through space, encounter different types of interference - fading. Various methods are used to improve signal performance, but the most commonly used are diversity techniques. The most commonly used combining techniques are: SC - Selective Combining, MRC - Maximal Ratio Combining and EGC - Equal Gain Combining [1].

MRC diversity technique gives the best results [2,3]. This technique effectively reduces the impact of fading on system performance and gives the greatest diversity gain. The signal-to-noise ratio at the output of the MRC receiver is equal to the sum of the signal-to-noise ratio at its inputs. If the noise power is the same in all diversity branches, then the square of the signal at the output is equal to the sum of the square of the signal at its inputs. This method requires that the signals at the inputs be brought into phase. That is why this way of combining is complex and expensive for practical implementation, Figure 1.

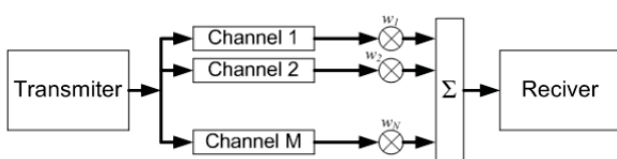

*Fig. 1. MRC diversity system*

EGC diversity technique is a compromise solution. It gives better performance than SC receiver and worse than MRC receiver. The signal envelope at the output of the EGC receiver is equal to the sum of the signal envelopes at its inputs. The EGC receiver requires information about the channel and requires that the signals at the inputs to the EGC diversity receiver are brought into phase, Figure 2.

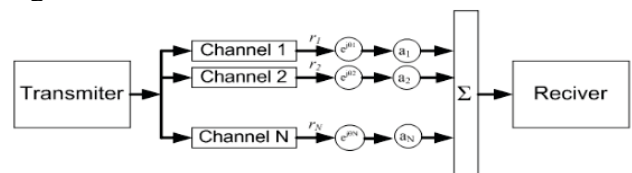

*Fig. 2. EGC diversity system*

The SC diversity technique is simple for practical implementation because the processing is done only on one diversity branch. The SC receiver selects the branch with the highest signal-to-noise ratio. If the noise power is the same in all branches, then the SC receiver selects the branch with the strongest signal, Figure 3.

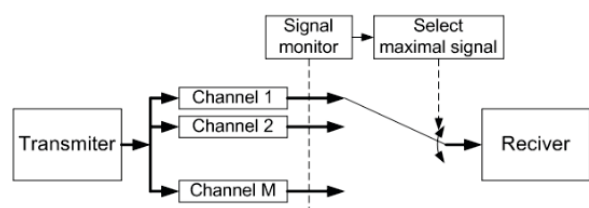

*Fig. 3. SC diversity system*

**EXPOSITION**

The paper analyzes a macro diversity system consisting of three SC micro diversity systems with three inputs each. Each micro-diversity system has three inputs and each output from the micro-diversity system is connected to the input of the macro-diversity combiner [4,5]. The micro-diversity combiner of the system is of the form SC and the macro-diversity combiner of the system is the selective SC, by power and by channel. Nakagami - m fading appears at the input of the first micro diversity combiner, Rayleigh fading at the input of the second micro diversity combiner, and Rice fading at the input of the third micro diversity combiner. All signals at the inputs to the combiner are independent. The power of Nakagami - m fading is  $\Omega_1$ , the power of Rayleigh fading is  $\Omega_2$ , and the power of Rice fading is  $\Omega_3$ , they are dependent, i.e. correlated, and variable. Powers  $\Omega_1$ ,  $\Omega_2$  and  $\Omega_3$  have a log-normal probability density, Figure 4.

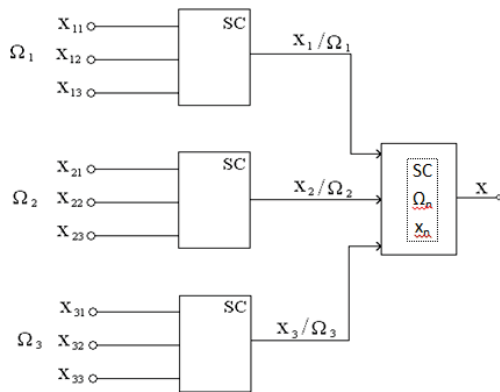

Fig. 4 System model

The signals at the inputs of the first micro diversity system are  $x_{11}, x_{12}$  and  $x_{13}$ . These signals are mutually independent and have an identical Nakagami distribution. Also, these signals at the input of the first micro diversity system have the same strength  $\Omega_1$ . The first micro diversity combiner is used to reduce the impact of Nakagami fading on system performance. Signal probability densities are, equation 1:

$$\begin{aligned}
 p_{x_{11}}(x_{11}) &= \frac{2}{\Gamma(m)} \left( \frac{m}{\Omega_1} \right)^m x_{11}^{2m-1} e^{-\frac{m}{\Omega_1} x_{11}} \\
 p_{x_{12}}(x_{12}) &= \frac{2}{\Gamma(m)} \left( \frac{m}{\Omega_1} \right)^m x_{12}^{2m-1} e^{-\frac{m}{\Omega_1} x_{12}} \\
 p_{x_{13}}(x_{13}) &= \frac{2}{\Gamma(m)} \left( \frac{m}{\Omega_1} \right)^m x_{13}^{2m-1} e^{-\frac{m}{\Omega_1} x_{13}}
 \end{aligned}
 \tag{1}$$

where  $m$  is the fading sharpness.

The signals at the inputs of the second micro diversity combiners are  $x_{21}, x_{22}$  and  $x_{23}$ . These signals are mutually independent and have identical Rayleigh probability density function. Model is used to mitigate the effect of Rayleigh fading on system performance. Signal strengths at the inputs of this micro diversity combiner are  $\Omega_2$ . The signal probability densities are, equation 2:

$$\begin{aligned}
 p_{x_{21}}(x_{21}) &= \frac{x_{21}}{\Omega_2} e^{-\frac{x_{21}^2}{2\Omega_2}} \\
 p_{x_{22}}(x_{22}) &= \frac{x_{22}}{\Omega_2} e^{-\frac{x_{22}^2}{2\Omega_2}} \\
 p_{x_{23}}(x_{23}) &= \frac{x_{23}}{\Omega_2} e^{-\frac{x_{23}^2}{2\Omega_2}}
 \end{aligned}
 \tag{2}$$

The signals at the inputs of the third micro diversity combine are  $x_{31}, x_{32}$  and  $x_{33}$ . These signals are mutually independent and have identical Rice probability density. A third micro diversity system is used to reduce the effect of Rice fading on system performance. Signal strengths at the inputs of this micro diversity combiner are  $\Omega_3$ . Signal probability densities are, equation 3:

$$\begin{aligned}
 p_{x_{31}}(x_{31}) &= \frac{x_{31}}{\Omega_3} \cdot \exp\left(-\frac{x_{31}^2 + A^2}{2\Omega_3}\right) \cdot I_0\left(\frac{x_{31}A}{\Omega_3}\right) \\
 p_{x_{32}}(x_{32}) &= \frac{x_{32}}{\Omega_3} \cdot \exp\left(-\frac{x_{32}^2 + A^2}{2\Omega_3}\right) \cdot I_0\left(\frac{x_{32}A}{\Omega_3}\right) \\
 p_{x_{33}}(x_{33}) &= \frac{x_{33}}{\Omega_3} \cdot \exp\left(-\frac{x_{33}^2 + A^2}{2\Omega_3}\right) \cdot I_0\left(\frac{x_{33}A}{\Omega_3}\right)
 \end{aligned}
 \tag{3}$$

where A is the amplitude of the dominant component.

The cumulative probability of a random variable is defined as the probability that this random variable is less than some value. Cumulative probabilities for random variables  $x_{11}, x_{12}$  and  $x_{13}$  are, equation 4 :

$$\begin{aligned} F_{x_{11}}(x_{11}) &= \frac{1}{\Gamma(m)} \cdot \gamma\left(m, x_{11}^2 \frac{m}{\Omega_1}\right) \\ F_{x_{12}}(x_{12}) &= \frac{1}{\Gamma(m)} \cdot \gamma\left(m, x_{12}^2 \frac{m}{\Omega_1}\right) \\ F_{x_{13}}(x_{13}) &= \frac{1}{\Gamma(m)} \cdot \gamma\left(m, x_{13}^2 \frac{m}{\Omega_1}\right) \end{aligned} \quad (4)$$

where  $\gamma(a,x)$  incomplete (Gamma) function. Cumulative probabilities for Rayleigh random variables  $x_{21}, x_{22}$  and  $x_{23}$  are, equation 5:

$$\begin{aligned} F_{x_{21}}(x_{21}) &= 1 - e^{-\frac{x_{21}^2}{2\Omega_2}} \\ F_{x_{22}}(x_{22}) &= 1 - e^{-\frac{x_{22}^2}{2\Omega_2}} \\ F_{x_{23}}(x_{23}) &= 1 - e^{-\frac{x_{23}^2}{2\Omega_2}} \end{aligned} \quad (5)$$

The cumulative probabilities for Rice's random variables  $x_{31}, x_{32}$  and  $x_{33}$  are, equation 6:

$$\begin{aligned} F_{x_{31}}(x_{31}) &= \frac{1}{\Omega_3} e^{-\frac{A^2}{2\Omega_3}} \int_0^{\frac{x_{31}^2}{2\Omega_3}} e^{-\frac{x^2}{2\Omega_3}} \cdot x \cdot \sum_{k=0}^{\infty} \left(\frac{A}{2\Omega_3}\right)^{2k} \frac{1}{k!} x^{2k} dx = \\ &= \frac{1}{\Omega_3} e^{-\frac{A^2}{2\Omega_3}} \cdot \sum_{k=0}^{\infty} \left(\frac{A}{2\Omega_3}\right)^{2k} \cdot \frac{1}{2k!} \cdot (2\Omega_3)^{1+k} \gamma\left(1+k, -\frac{x_{31}^2}{2\Omega_3}\right) \\ F_{x_{32}}(x_{32}) &= \frac{1}{\Omega_3} e^{-\frac{A^2}{2\Omega_3}} \cdot \sum_{k=0}^{\infty} \left(\frac{A}{2\Omega_3}\right)^{2k} \cdot \frac{1}{2k!} \cdot (2\Omega_3)^{1+k} \gamma\left(1+k, -\frac{x_{32}^2}{2\Omega_3}\right) \\ F_{x_{33}}(x_{33}) &= \frac{1}{\Omega_3} e^{-\frac{A^2}{2\Omega_3}} \cdot \sum_{k=0}^{\infty} \left(\frac{A}{2\Omega_3}\right)^{2k} \cdot \frac{1}{2k!} \cdot (2\Omega_3)^{1+k} \gamma\left(1+k, -\frac{x_{33}^2}{2\Omega_3}\right) \end{aligned} \quad (6)$$

The signal at the output of the first micro diversity combiner is  $x_1$ . Micro diversity combiner is selective. This means that the signal is  $x_1 = \max(x_{11}, x_{12}, x_{13})$ . Based on this, the conditional probability density of the signal  $x_1$ , conditional on power  $\Omega_1$ , is equal to, equation 7:

$$\begin{aligned} p_{x_1}(x_1/\Omega_1) &= p_{x_{11}}(x_1/\Omega_1) \cdot F_{x_{12}}(x_1/\Omega_1) \cdot F_{x_{13}}(x_1/\Omega_1) + \\ &+ p_{x_{12}}(x_1/\Omega_1) \cdot F_{x_{11}}(x_1/\Omega_1) \cdot F_{x_{13}}(x_1/\Omega_1) + \\ &+ p_{x_{13}}(x_1/\Omega_1) \cdot F_{x_{11}}(x_1/\Omega_1) \cdot F_{x_{12}}(x_1/\Omega_1) = \\ &= \frac{2}{\Gamma(m)} \cdot \left(\frac{m}{\Omega_1}\right)^m \cdot x_1^{2m-1} \cdot e^{-\frac{m}{\Omega_1} x_1^2} \cdot \frac{1}{\Gamma(m)} \cdot \gamma\left(m, \frac{m}{\Omega_1} x_1^2\right) \cdot \frac{1}{\Gamma(m)} \cdot \gamma\left(m, \frac{m}{\Omega_1} x_1^2\right) \cdot 3 = \\ &= \frac{6}{\Gamma(m)} \cdot \left(\frac{m}{\Omega_1}\right)^m \cdot x_1^{2m-1} \cdot e^{-\frac{m}{\Omega_1} x_1^2} \cdot \frac{1}{\Gamma^2(m)} \cdot \gamma^2\left(m, \frac{m}{\Omega_1} x_1^2\right) \end{aligned} \quad (7)$$

Based on the above, the probability density of the signal  $x_2$  can be written, equation 8:

$$\begin{aligned} p_{x_2}(x_2/\Omega_2) &= p_{x_{21}}(x_2/\Omega_2) \cdot F_{x_{22}}(x_2/\Omega_2) \cdot F_{x_{23}}(x_2/\Omega_2) + \\ &+ p_{x_{22}}(x_2/\Omega_2) \cdot F_{x_{21}}(x_2/\Omega_2) \cdot F_{x_{23}}(x_2/\Omega_2) + \\ &+ p_{x_{23}}(x_2/\Omega_2) \cdot F_{x_{21}}(x_2/\Omega_2) \cdot F_{x_{22}}(x_2/\Omega_2) = \\ &= \frac{3x_2}{\Omega_2} e^{-\frac{x_2^2}{2\Omega_2}} \left(1 - e^{-\frac{x_2^2}{2\Omega_2}}\right)^2 \end{aligned} \quad (8)$$

Based on this, the probability density of the signal  $x_3$  is, equation 9:

$$\begin{aligned} p_{x_3}(x_3/\Omega_3) &= p_{x_{31}}(x_3/\Omega_3) \cdot F_{x_{32}}(x_3/\Omega_3) \cdot F_{x_{33}}(x_3/\Omega_3) + \\ &+ p_{x_{32}}(x_3/\Omega_3) \cdot F_{x_{31}}(x_3/\Omega_3) \cdot F_{x_{33}}(x_3/\Omega_3) + \\ &+ p_{x_{33}}(x_3/\Omega_3) \cdot F_{x_{31}}(x_3/\Omega_3) \cdot F_{x_{32}}(x_3/\Omega_3) = \\ &= 3 \cdot \frac{x_3}{\Omega_3} \cdot e^{-\frac{x_3^2 + A^2}{2\Omega_3}} \cdot I_0\left(\frac{x_3 A}{\Omega_3}\right) \cdot \left[\frac{1}{\Omega_3} \cdot e^{-\frac{A^2}{2\Omega_3}} \cdot \sum_{k=0}^{\infty} \left(\frac{A}{2\Omega_3}\right)^{2k} \frac{1}{k!} (2\Omega_3)^{1+k} \gamma\left(1+k, -\frac{x_3^2}{2\Omega_3}\right)\right]^2 \end{aligned} \quad (9)$$

Signal strengths  $\Omega_1, \Omega_2$  and  $\Omega_3$  are variable due to the influence of slow fading caused by the shadow effect. The distance between macro diversities of the system is such that the powers  $\Omega_1, \Omega_2$  and  $\Omega_3$  are correlated. A macro diversity system is used to reduce the impact of slow fading on system performance. The combined probability density of the signal power  $\Omega_1, \Omega_2$  and  $\Omega_3$  is log-normal and is equal to, equation 10:

$$\begin{aligned} p_{\Omega_1 \Omega_2 \Omega_3}(\Omega_1, \Omega_2, \Omega_3) &= \frac{1}{(\sqrt{2\pi})^3 \sigma^3 \sqrt{1-r_{12} r_{13} r_{23}}} \cdot \exp\left\{-\frac{1}{2\sigma^2(1-r)} \left[(\ln \Omega_1 - \mu_1)^2 + (\ln \Omega_2 - \mu_2)^2 + \right. \right. \\ &+ (\ln \Omega_3 - \mu_3)^2 - 2r_{12}(\ln \Omega_1 - \mu_1)(\ln \Omega_2 - \mu_2) - 2r_{13}(\ln \Omega_1 - \mu_1)(\ln \Omega_3 - \mu_3) - 2r_{23}(\ln \Omega_2 - \mu_2)(\ln \Omega_3 - \mu_3)\left. \right\} \end{aligned} \quad (10)$$

The signals  $x_1, x_2$  and  $x_3$  are connected to the inputs of the combiner macro diversity system. The signal at the output of the macro diversity system is  $x$ . This combiner can be selective by the strength of the input signals and by the amplitude of the signal at the output

of the micro diversity combiner. First, the case is considered when the macro diversity combiner decides according to the signal strength at the inputs of the micro diversity combiner.

Based on this, the probability density of the signal  $x$  at the output of the macro diversity combine is equal to, equation 11:

$$p_x(x) = \int_0^\infty d\Omega_1 \int_0^\infty d\Omega_2 \int_0^\infty d\Omega_3 \cdot p_{x_1}(x_1/\Omega_1) \cdot p_{\Omega_1\Omega_2\Omega_3}(\Omega_1\Omega_2\Omega_3) + \int_0^\infty d\Omega_2 \int_0^\infty d\Omega_1 \int_0^\infty d\Omega_3 \cdot p_{x_2}(x_2/\Omega_2) \cdot p_{\Omega_1\Omega_2\Omega_3}(\Omega_1\Omega_2\Omega_3) + \int_0^\infty d\Omega_3 \int_0^\infty d\Omega_1 \int_0^\infty d\Omega_2 \cdot p_{x_3}(x_3/\Omega_3) \cdot p_{\Omega_1\Omega_2\Omega_3}(\Omega_1\Omega_2\Omega_3) \quad (11)$$

If the macro diversity combiner decides according to the amplitude of the output signals of the micro diversity combiner, then the probability density of the signal  $x$  is equal to, equation 12:

$$p_x(x) = \int_0^\infty d\Omega_1 \int_0^\infty d\Omega_2 \int_0^\infty d\Omega_3 \cdot p_{\Omega_1\Omega_2\Omega_3}(\Omega_1\Omega_2\Omega_3) \cdot p_{x_1}(x/\Omega_1) \cdot F_{x_2}(x/\Omega_2) \cdot F_{x_3}(x/\Omega_3) + \int_0^\infty d\Omega_1 \int_0^\infty d\Omega_2 \int_0^\infty d\Omega_3 \cdot p_{\Omega_1\Omega_2\Omega_3}(\Omega_1\Omega_2\Omega_3) \cdot p_{x_2}(x/\Omega_2) \cdot F_{x_1}(x/\Omega_1) \cdot F_{x_3}(x/\Omega_3) + \int_0^\infty d\Omega_1 \int_0^\infty d\Omega_2 \int_0^\infty d\Omega_3 \cdot p_{\Omega_1\Omega_2\Omega_3}(\Omega_1\Omega_2\Omega_3) \cdot p_{x_3}(x/\Omega_3) \cdot F_{x_1}(x/\Omega_1) \cdot F_{x_2}(x/\Omega_2) \quad (12)$$

Cumulative probabilities of signals  $x_1, x_2$  and  $x_3$  are calculated according to the following equation 13:

$$F_{x_1}\left(\frac{x_1}{\Omega_1}\right) = \int_0^{x_1} p_{x_1}\left(\frac{t}{\Omega_1}\right) dt = \int_0^{x_1} \left\{ \frac{6}{\Gamma(m)} \cdot \left(\frac{m}{\Omega_1}\right)^m \cdot x_1^{2m-1} \cdot e^{-\frac{m}{\Omega_1}x_1^2} \cdot \frac{1}{\Gamma^2(m)} \cdot \gamma^2\left(m, \frac{m}{\Omega_1}x_1^2\right) \right\} dt$$

$$F_{x_2}\left(\frac{x_2}{\Omega_2}\right) = \int_0^{x_2} p_{x_2}\left(\frac{t}{\Omega_2}\right) dt = \int_0^{x_2} \left\{ \frac{3x_2}{\Omega_2} \cdot e^{-\frac{x_2^2}{2\Omega_2}} \cdot \left(1 - e^{-\frac{x_2^2}{2\Omega_2}}\right)^2 \right\} dt$$

$$F_{x_3}\left(\frac{x_3}{\Omega_3}\right) = \int_0^{x_3} p_{x_3}\left(\frac{t}{\Omega_3}\right) dt = \int_0^{x_3} \left\{ \frac{3 \cdot x_3}{\Omega_3} \cdot e^{-\frac{x_3^2 + A^2}{2\Omega_3}} \cdot I_0\left(\frac{x_3 A}{\Omega_3}\right) \cdot \left[ \frac{1}{\Omega_3} \cdot e^{-\frac{A^2}{2\Omega_3}} \cdot \sum_{k=0}^{\infty} \left(\frac{A}{2\Omega_3}\right)^2 \frac{1}{k!} (2\Omega_3)^{1+k} \cdot \gamma\left(1+k, -\frac{x_3^2}{2\Omega_3}\right) \right]^2 \right\} dt \quad (13)$$

Table 1 shows the results for different L-branch diversities with MRC, SC and EGC combining in the Rayleigh channel and BPSK modulation with L branches.

Table 1

Summary results for the Rayleigh channel			
Sr. No.	SC	EGC	MRC
L1	8.95E-02	8.90E-02	8.00E-02
L2	1.56E-02	9.99E-03	9.83E-03
L3	6.75E-03	9.89E-04	9.10E-04
L4	4.33E-03	1.95E-05	1.05E-05

The following MATLAB figure 5 determines the comparative characteristics of SC, EGC and MRC combining in Rayleigh channel and BPSK modulation.

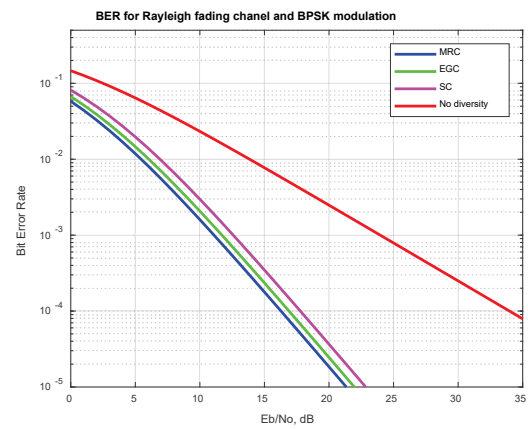

Fig. 5 Advantages of SC, EGC and MRC combination

We can conclude that compared to the theoretical curve, a significant reduction in fading has been achieved. It can be seen that by applying the EGC and SC combination, the BER curve gives less favorable results than the MRC.

Figure 6 represents the BER diversity gain in relation to the maximum signal values.

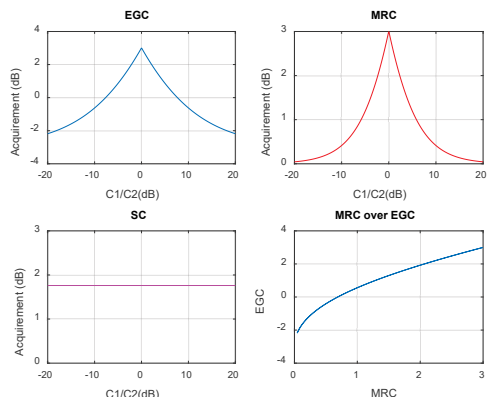

Fig. 6 Advantages of diversity acquirement

Probability density function can be used to calculate the error probability of a modulated signal [6]. The probability density of the signal at the output of the digital system can be used to determine the probability of system failure.

Using the bit error probability and the failure probability, the signal strength will be determined depending on the interference parameters.

## REFERENCE

- [1] A. Annamalai, C. Tellambura, and Vijay K. Bhargava, "Equal gain diversity receiver performance in wireless channels", IEEE Trans. Commun. vol 48, Oct 2000.
- [2] L. Fang, G. Biand A.C.Kot,"New method of performance analysis for diversity reception with correlated Rayleigh fading signals", IEEE Trans.Veh.Technol.vol 49, Sept. 2000.
- [3] B. Milosevic, J.Srdjan, M., "Categories of fading effects and diversity solutions", UNITECH 2007, Gabrovo, Bulgaria.
- [4] G. M. Vitetta, U. Mengali, and D. P. Taylor, "An error probability formula for noncoherent orthogonal binary FSK with dual diversity on correlated Rician channels", IEEE Trans. Commun., Lett.Feb. 1999.
- [5] S.Jovković, B.Milošević, S.Obradović, "Interferences in wireless channel model of a body area network",UNITECH 2016 – Gabrovo, Bulgaria
- [6] A. Annamalai, C. Tellambura, and V. K. Bhargava, "Unified analysis of MPSK and MDPSK with diversity reception in different fading environments," Electron. Lett., pp. 1564–1565, Aug. 1998.